

# S

## SERIES



SVEBA DAHLEN



# Optimized baking results in store

**Bake everything from bread rolls and sourdough bread to delicate pastries to perfection with the ultra-modern S-Series mini rack oven. Achieve similar results, efficiency and functionality to that of an industrial rack oven. Designed to occupy minimal space, the S-Series is optimized for smaller bakeries and store use. Equipped with a modern digital control panel, optimized airflow as well as rotation speed, heating and steam systems. The combination oven that allows simpler, cheaper, more efficient and better baking.**

The S-Series is a compact rack oven with high capacity, efficiency and flexibility. The oven is equipped with modern SD Touch II digital panels which offer all the practical features that a modern oven requires; compatibility with Sveba Connect cloud service, programmable weekly schedule, recipe management, half rack function for partially filled racks, cake function with pulse fan mode for baking delicate pastries and a power-saving mode that shuts off energy-intensive functions and drops to the desired resting temperature when baking is not in progress.

The series is equipped with our own patented IBS system, for alternate rack rotation inside the oven. The IBS system provides faster, more even and more energy-efficient baking. The S-Series also has a built-in steam system with very high capacity. The system can be programmed to use the desired amount of steam, and when to turn it on and off.

With optimized airflow, as well as rotation speed, steam and temperature, the S-Series offers world-class baking in a compact size. The maximum baking temperature is 300°C.

# SD Touch II - next generation smart control panel

Time-saving, energy-efficient baking plus smart baking functions with the SD Touch II. The panel makes everyday baking easier and helps the baker get the best possible results. Time-saving functions are available, such as programmable weekly schedules and recipe management. Achieve the perfect results with precision to the second in baking times, heat settings and steam supply. Baking settings are so simple that anyone can get started with a bake. User-friendly and modern touch panel with clear interface, high definition display, sharp contrast and swipe function. The panel controls the oven's processes, including steam and power saving mode. Can be connected to the Sveba Connect cloud service, but also has features for reading the energy consumption directly from the panel. Time-saving and energy-efficient baking with the best result!

## PROPERTIES AND FUNCTIONALITY

- **Connect to the cloud**
  - Sveba Connect.
  - Update the panel software with just one click.
  - Servicing information, statistics and an overview of all the connected ovens, in real time.
  - Upload, download and share recipes.
- **Half-rack function**
  - Adjust the temperature, steam, baking time and damper time by a factor of 0 to 1, where 1 is a full rack, to suit partially filled oven racks. Saved settings are activated with a single click.
- **Recipe management**
  - Save recipes.
  - Exact timings to the minute and second for baking time, temperature, steam and more.
  - Add recipes to Favorites for quick access.
- **Modern touch screen**
  - Vertical swipe function.
  - High resolution display.
- **Easy clean**
  - Dust and moisture resistant panel.
  - Frameless display at the level of the baking tray.
- **Programmable weekly schedule**
  - Prepare work for the week.
  - Provide the desired oven temperature and the start/end times.
  - The oven is then pre-heated by the start of the working day.
- **Statistics and graphs**
  - Energy and cost graphs shown directly on the panel.
  - Track user statistics from several years ago up to present day.

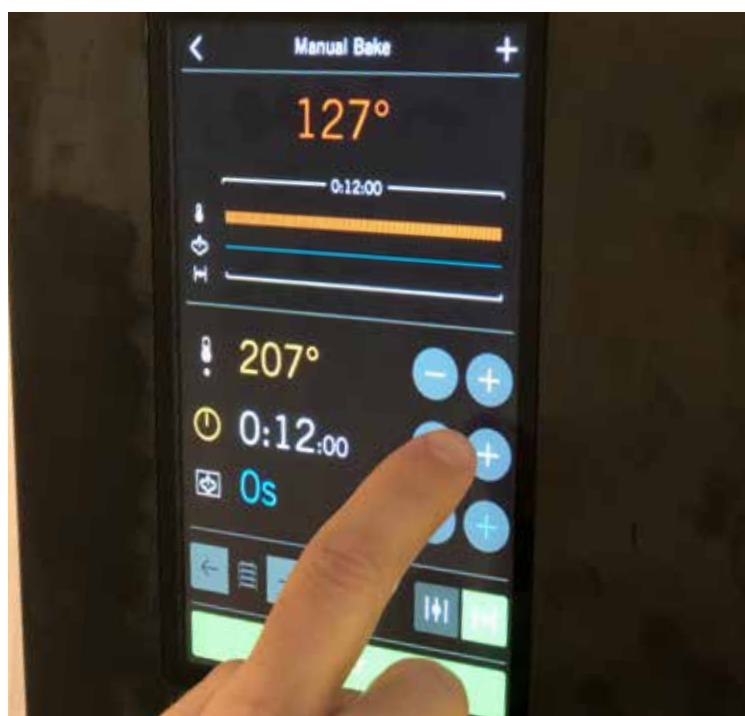



### Airflow

A horizontal airflow developed to give a very even baking result across the rack, even for delicate bakes with short baking times. The airflow also affords better efficiency and consequently lower heating costs.



### Rotation

Rotating rack with optimized rotation speed and automatic change of rack rotation direction, gives an even bake with better results.



### Steam system

A uniquely developed steam system with both even and efficient capacity, as well as rapid recovery, resulting in a greater production capacity.

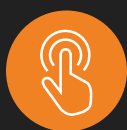

### Control panel

A user-friendly, smart control panel that gives the user complete control of the entire baking process.



### Sveba Connect (option)

Compatible with Sveba Dahlen's cloud service for ovens. Overview of all connected ovens in real time. Save money, maximize the bakery's efficiency, get statistics, service information, important notifications and have full control of the recipe bank.



## PROPERTIES AND FUNCTIONALITY

The S-Series is a compact and energy-efficient mini rack oven with an industrial feel, adapted to the needs of a supermarket bakery or smaller-volume bakery. Available in three sizes: SR120, SR130 and SR240. The oven comes in stainless steel as standard, plus an optional black design.

### 1. Flexible baking with the best results

Made from sturdy materials and tried-and-tested components to guarantee performance and a long service life. With optimized air flow, rotation and heat, as well as with smart built-in functions and a professional high-capacity steam system, the S-Series offers highly flexible baking. Bakes everything from delicate biscuits to larger pastries, rolls, sourdough bread and macarons to perfection. Space for 6 or 10 trays in a standard rack. The maximum baking temperature is 300°C.

### 2. Increased Baking Surface (IBS)

A patented system for alternate rack rotation inside the oven. The IBS system provides faster, more even and more energy-efficient baking.

### 3. Integrated, programable, high-capacity steam system

Settings for how much steam is released and when it should be turned on and off. Gives a smooth, crisp crust and for some breads a significantly increased volume.

### 4. SD Touch II - smart digital control panel

SD Touch II is user-friendly with a clear user interface, as well as touch and swipe functionality. With features that facilitate a bakery's work, such as recipe management, a programmable weekly schedule, half-rack function, cake function for delicate products and compatibility to the Sveba Connect cloud service. Have full control of consumption and costs with statistical graphs. Achieve baking settings with to-the-second precision and get full control over baking and better and more accurate baking results than ever before.

### 5. Energy-efficient

Customized features for baking with low energy consumption. The components and features are customized to offer the lowest cost for baking. To save energy, the control panel offers a power-saving mode that turns off the lights, closes the damper and regulates the fan speed to low.

### 6. Steam-free working environment

The extractor canopy effectively catches heat and steam when the oven door is opened. The optional condensation unit effectively removes steam and moisture in the oven, which means an improved working environment.

### 7. Robust, movable design gives a long service life

Made of sturdy, stainless steel that is easy to keep clean. Two lockable wheels allow easy handling and movement.

### 8. Heat-reflecting oven window

The door is fitted with a large heat-reflecting double glazed window. Efficient halogen light illuminates the oven compartment and gives the baker a clear overview of the baking process. This therefore tempts customers to buy products in store when they see the tasty pastries rotating inside the oven with the pleasant lighting.

We are working on certifying our products. Contact your dealer for the latest certification information.





# Proofing perfection, directly in store

**The S-Series proofer offers absolute world-class proofing. Together with the S-Series rack oven, the S-Series creates a hard-to-beat combination of the highest class flexibility and baking options. The carefully engineered design provides a stable temperature internally. The proofer's control panel controls temperature and humidity individually, giving total control over the proofing process. Optimal proofing in a compact space!**

The design and functionality of the cabinet means an optimal proofing process without risking over-proofing and dehydrated doughs. Despite the compact design, the proofing cabinet has a high capacity with room for up to 10 baking trays.

The proofing process is easily controlled via the digital, user-friendly control panel with individual temperature and humidity settings and timer.

The large window in the door and the clear light from the LED strip inside the cabinet make it easy to monitor the proofing process on all the trays.

The stainless steel and simple design makes the proofer cabinet easy to clean. Excess condensation is efficiently collected via a channel in the door.

## Check the proofing process - user-friendly digital control panel

The proofer beneath the oven with its digital control panel easily manages the proofing process with just a few clicks. With simple settings, the temperature and ambient humidity of the cabinet are adjusted separately for full proofing control.

### PROPERTIES AND FUNCTIONALITY

- **Temperature**
  - See the current temperature inside the cabinet.
  - Enter the desired proofing temperature.
  - Adjust the temperature depending on the dough type.
- **Humidity**
  - See the current humidity inside the cabinet.
  - Enter the desired humidity.
  - Adjust the humidity depending on dough type.
- **Timer**
  - Enter the desired proofing time.
  - Beep sounds when the proofing program is complete.
- **Easy cleaning**
  - Glass screen.
  - Dust and moisture-resistant panel.
  - Frameless screen.
- **Audio signal**
  - Audio signal when the program is complete.
  - Audio signal in the event of any fault codes.





### Energy efficiency

High energy efficiency thanks to intelligent energy-saving features and a well-insulated proving cabinet.



### Temperature and humidity

Temperature and humidity are set separately. Ensure optimal control for proofing.





# PROPERTIES AND FUNCTIONALITY

## UNDERBUILT PROOFER

S-Series proofer - SP, can be used as a separate proofing cabinet, or combined with S-Series rack ovens as a smooth and space-efficient complete solution with oven and proofing cabinet in one. The proofer is equipped with an automatic water feed as well as humidity and temperature sensors. The cabinet is available in two sizes, SP1 and SP2.

### 1. Digital control panel

User-friendly control panel with functions for temperature- and humidity settings and timer.

### 2. Optimal proofing

Fitted with EHDS - Effective Humidity Distribution System, which generates optimal distribution of steam in the proofing cabinet. The cabinet also has an automatic water feed, temperature and humidity sensors as well as an optimized circulation fan.

### 3. Flexible proofing

The proofing is adjusted using the temperature and humidity settings in the control panel. Easy adjustment of the guides to fit the desired tray size. Space for up to 10 baking trays. Ambient temperature to +60°C.

### 4. Good overview of the proofing process

Large window in the door and vertical LED strip inside the cabinet gives a clear view of the entire proofing process on all the trays, without needing to open the door.

### 5. Robust construction

Made from stainless steel and high quality materials, ensuring a long service life. Drainage in proofing cabinet to lead away condensation. Stable doors that are easy to open and close. Robust wheels, two of which are lockable.

### 6. Energy-efficient

The cabinet maintains an even, stable temperature and preserves heat inside the proofing area.

### 7. Easy cleaning

The proofing cabinet is made from stainless steel and has a jointless floor. The guides can easily be removed for simple cleaning of the proofing cabinet. The guides can be put in the dishwasher. The control panel has a glass screen that can easily be wiped down.

## TECHNICAL SPECIFICATIONS

### SR120 / SRP120



	SR120 - Oven	SP1 - Proofing cabinet
Max. baking temperature	300°C	-
Max. tray depth	600 mm	600 mm
Max. tray width	400 mm	800 mm
Max. no of trays 400 x 600 mm	6 pcs	10 pcs
Max. no of trays 800 x 600 mm	-	5 pcs
Max. dough weight	18 kg	25 kg
Power kW	14.3 kW	1.4 kW
Average consumption**	8.6 kW/h	0.84 kW/h
External dimensions mm - W x D x H	990 x 953 x 2031 mm	990 x 953 x 635 mm
Weight	275 kg	124 kg
Door swing radius	600 mm	737 mm

### SR130 / SRP130



	SR130 - Oven	SP1 - Proofing cabinet
Max. baking temperature	300°C	-
Max. tray depth	600 mm	600 mm
Max. tray width	400 mm	800 mm
Max. no of trays 400 x 600 mm	10 pcs	10 pcs
Max. no of trays 800 x 600 mm	-	5 pcs
Max. dough weight	30 kg	25 kg
Power kW	21.2 kW	1.4 kW
Average consumption**	12.7 kW/h	0.84 kW/h
External dimensions mm - W x D x H	990 x 953 x 2245 mm	990 x 953 x 635 mm
Weight	341 kg	124 kg
Door swing radius	600 mm	737 mm

### SR240 / SRP240



	SR240 - Oven	SP2 - Proofing cabinet
Max. baking temperature	300°C	-
Max. tray depth *	700 mm	700 mm
Max. tray width *	470 mm	470 mm
Max. diagonal tray Ø mm	806 mm	-
Max. no of trays 400 x 600 mm	10 pcs	10 pcs
Max. no of trays 800 x 600 mm	-	-
Max. dough weight	40 kg	40 kg
Power kW	21.2 kW	1.4 kW
Average consumption**	12.7 kW/h	0.84 kW/h
External dimensions mm - W x D x H	1168 x 953 x 2245 mm	1168 x 953 x 635 mm
Weight	360 kg	140 kg
Door swing radius	778 mm	623 mm

\* For exact tray dimensions: sveba.com or check the user manual.

\*\* During continuous baking. Approx. 60% of installed power.

## DRAWINGS AND DIMENSIONS [MM]

### SR120 / SRP120

Space for 6 baking trays.

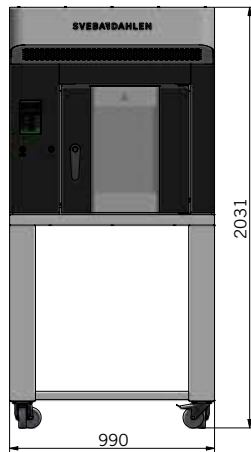

**SR120**



**SRP120**

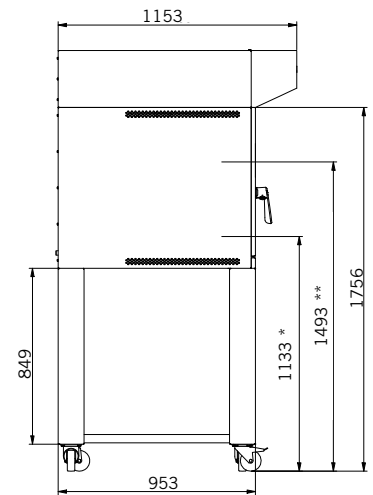

**SR120 / SRP120**

### SR130 / SRP130

Space for 10 baking trays.

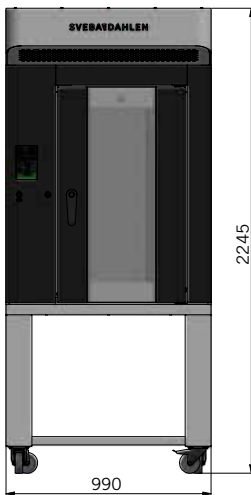

**SR130**



**SRP130**

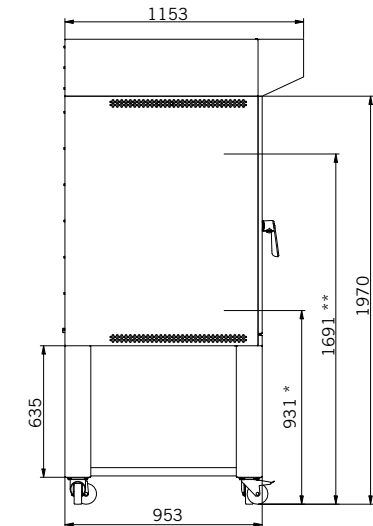

**SR130 / SRP130**

### SR240 / SRP240

Space for 10 baking trays.

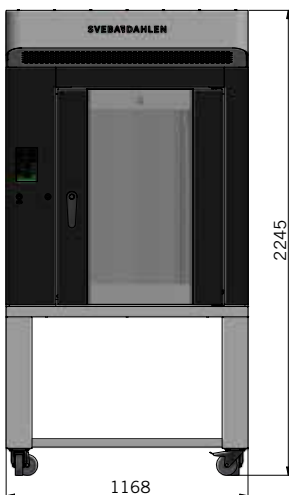

**SR240**



**SRP240**

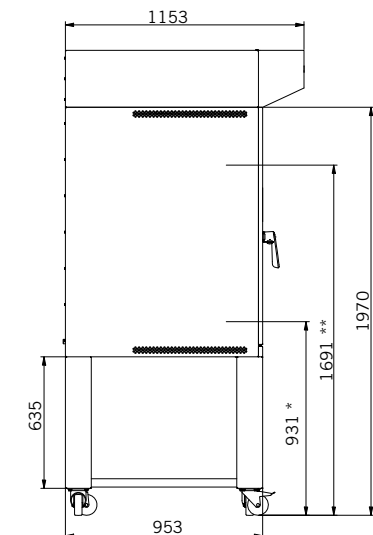

**SR240 / SRP240**

With the front removed, the oven can run through a normal doorway  
(IMPORTANT - Min. measurement for doorway: 895 mm required + note the oven height).

\* lowest baking tray setting.  
\*\* highest baking tray setting.

**We believe in high performing, energy efficient and user-friendly equipment.**

We offer reliable technology that allows the professionals of the baking industry creative freedom at the lowest cost of ownership.

We become the professional business partner throughout the baking process, with an accessible organization, user-friendly designs and precisely controlled, reliable equipment.

**Sveba Dahlen AB**

Industrivägen 8

SE-513 82 Fristad, Sweden

[www.sveba.com](http://www.sveba.com)

[info@sveba.com](mailto:info@sveba.com)

